

Product data sheet

Specifications

SQUARE D

Green Premium™



Circuit breaker, PowerPact J, 200A, 3 pole, 600VAC, 25kA, lugs, thermal magnetic, 80%

JLL36200

Product availability : Stock - Normally stocked in distribution facility

Price* : 5,432.00 USD

Main

Range	PowerPact
Product name	PowerPact J
Product or Component Type	Circuit breaker
Device Application	Distribution

Complementary

Line Rated Current	200 A
Number of Poles	3P
Control Type	Toggle
Breaking capacity code	J
Breaking capacity	100 kA 240 V AC 50/60 Hz UL 489 65 kA 480 V AC 50/60 Hz UL 489 25 kA 600 V AC 50/60 Hz UL 489 20 kA 250 V DC UL 489
[Ue] rated operational voltage	600 V AC 50/60 Hz IEC 60947-3
Network Frequency	50/60 Hz
[Ics] rated service breaking capacity	65 kA 220/240 V AC 50/60 Hz IEC 60947-2 35 kA 380/440/415 V AC 50/60 Hz IEC 60947-2 18 kA 500/525 V AC 50/60 Hz IEC 60947-2 20 kA 250 V DC IEC 60947-2 20 kA 500 V DC IEC 60947-2
[Uimp] rated impulse withstand voltage	8 kV IEC 60947-2
Trip unit technology	Thermal-magnetic
Magnetic tripping current	2000 A
Magnetic hold current	1000 A
Continuous current rating	80 %
[Ui] rated insulation voltage	750 V IEC 60947-2
Protection Type	Overload protection Short-circuit protection
Suitability for isolation	Yes IEC 60947-2
Utilisation category	Category A
AWG gauge	AWG 3/0...350 kcmil aluminium/copper terminals

* Price is "List Price" and may be subject to a trade discount – check with your local distributor or retailer for actual price.

Local signalling	Switched off (OFF) 1 trip indicator green)
Mounting mode	Unit mount lug)
Mounting Support	Lug
Electrical connection	Lugs line Lugs load
Terminal identifier	AL250JD
Long time pick-up adjustment range	0.25...1 x In
Mounting Height	4.5 in (114.30 mm)
Tightening torque	221.27 lbf.in (25 N.m) 0.15...0.29 in ² (95...185 mm ²) (AWG 3/0...350 kcmil)
Number of slots	2 auxiliary switch OF plug-in) 1 alarm switch SD plug-in) 1 overcurrent trip switch SDE plug-in) 1 voltage release MN or MX plug-in)
Power wire stripping length	0.98 in (25 mm)
Height	7.52 in (191 mm)
Width	4.09 in (104 mm)
Depth	3.39 in (86 mm)
Net Weight	5.29 lb(US) (2.4 kg)
Phase connection	ABC
Communication interface	Modbus Ethernet

Environment

Quality labels	CE
Standards	UL CSA NEMA NOM-003-SCFI-2000 IEC 60947-2
Product certifications	UL CSA NOM
IP degree of protection	Front cover IP40
Pollution degree	3 IEC 60947-1
Ambient Air Temperature for Operation	28...158 °F (-2...70 °C)
Ambient Air Temperature for Storage	-58...185 °F (-50...85 °C)
Operating altitude	< 6561.68 ft (2000 m) without derating 5000 m with derating

Ordering and shipping details

Category	01115-HG,HJ,JG,JJ UNIT MT BREAKER/SWITCH
Discount Schedule	DE2
GTIN	785901461937
Nbr. of units in pkg.	1
Package weight(Lbs)	4.80 lb(US) (2.177 kg)
Returnability	Yes
Country of origin	MX

Packing Units

Unit Type of Package 1	PCE
Package 1 Height	5.70 in (14.478 cm)
Package 1 width	7.50 in (19.05 cm)
Package 1 Length	8.60 in (21.844 cm)

Offer Sustainability

Sustainable offer status	Green Premium product
California proposition 65	WARNING: This product can expose you to chemicals including: DINP, which is known to the State of California to cause cancer, and DIDP, which is known to the State of California to cause birth defects or other reproductive harm. For more information go to www.P65Warnings.ca.gov
REACH Regulation	REACH Declaration
EU RoHS Directive	Compliant EU RoHS Declaration
Mercury free	Yes
RoHS exemption information	Yes
China RoHS Regulation	China RoHS declaration Product out of China RoHS scope. Substance declaration for your information.
Environmental Disclosure	Product Environmental Profile
Circularity Profile	End of Life Information
WEEE	The product must be disposed on European Union markets following specific waste collection and never end up in rubbish bins.
PVC free	Yes

Contractual warranty

Warranty	18 months
----------	-----------

Approximate Dimensions

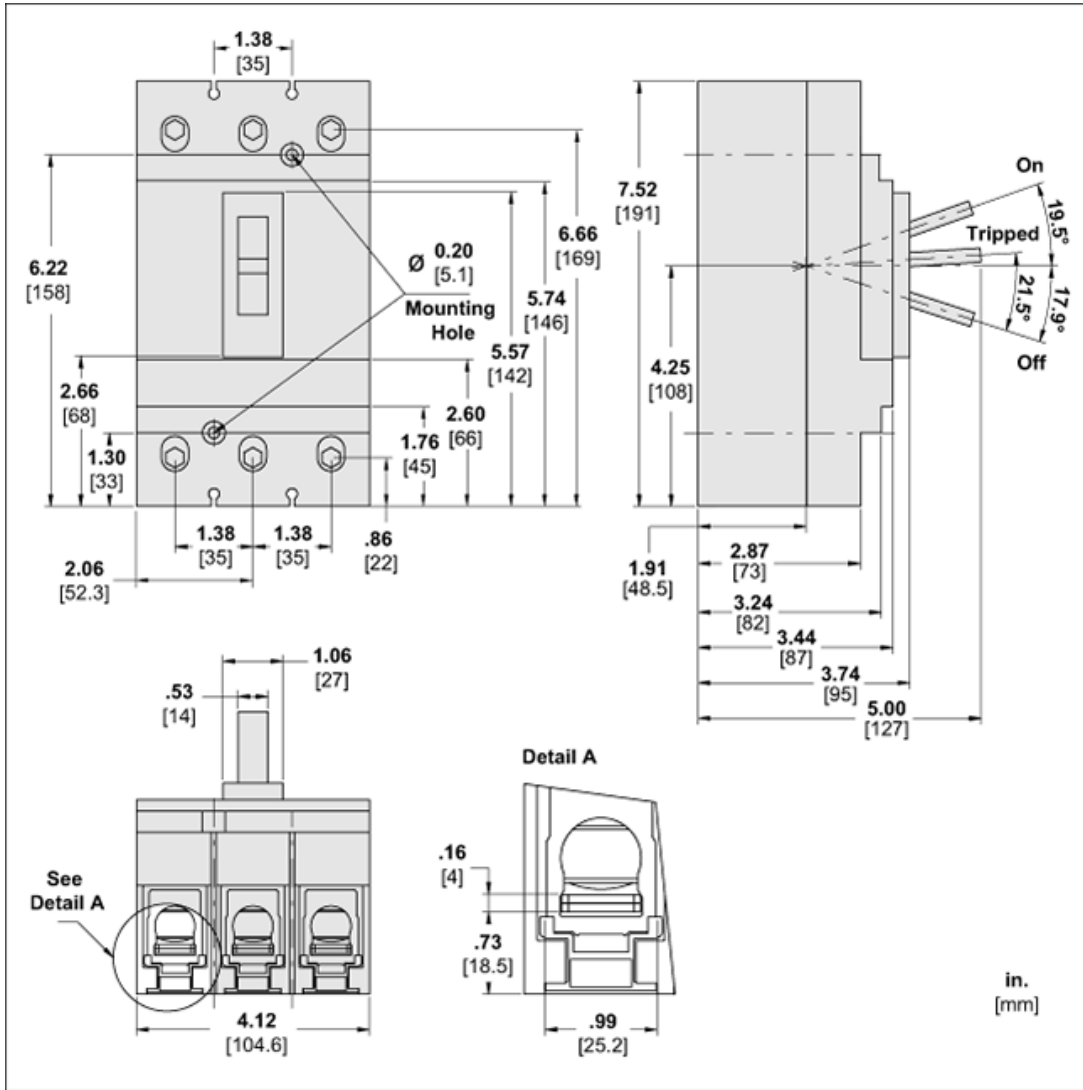

Dimensions

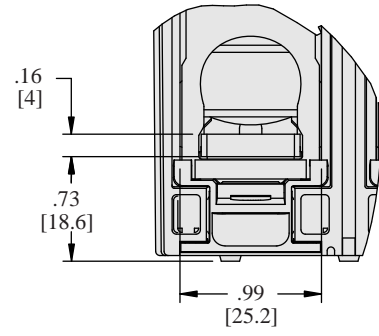
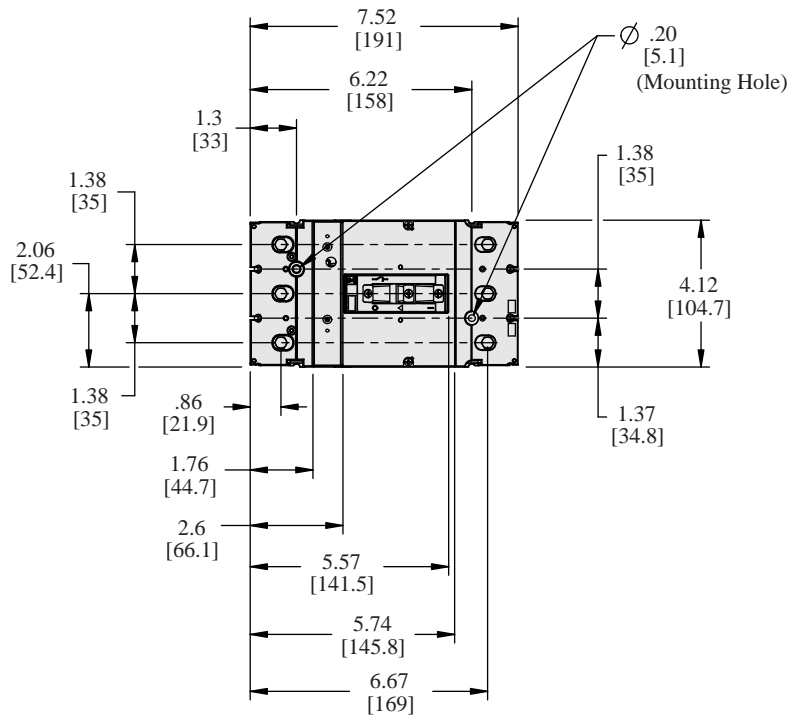

DETAIL A

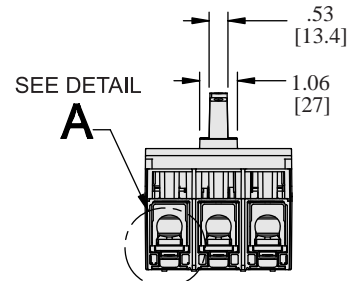
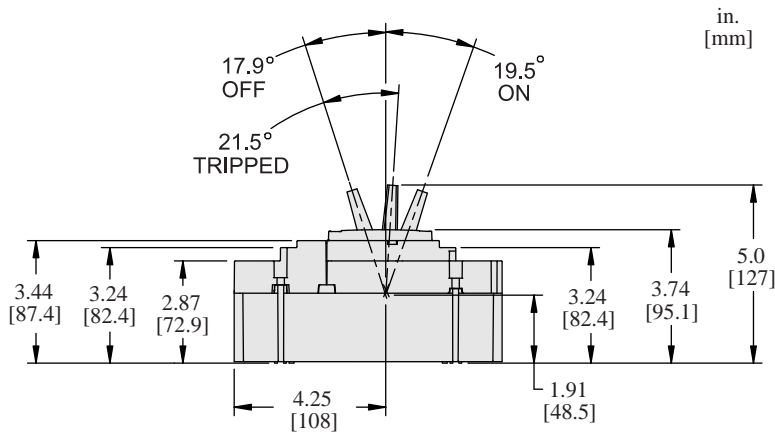

ALL DIMENSIONS ARE APPROXIMATE.
 ALSO REFER TO TECHNICAL DRAWINGS AND DOCUMENTATION.